

INTEGRATED ACTUATORS

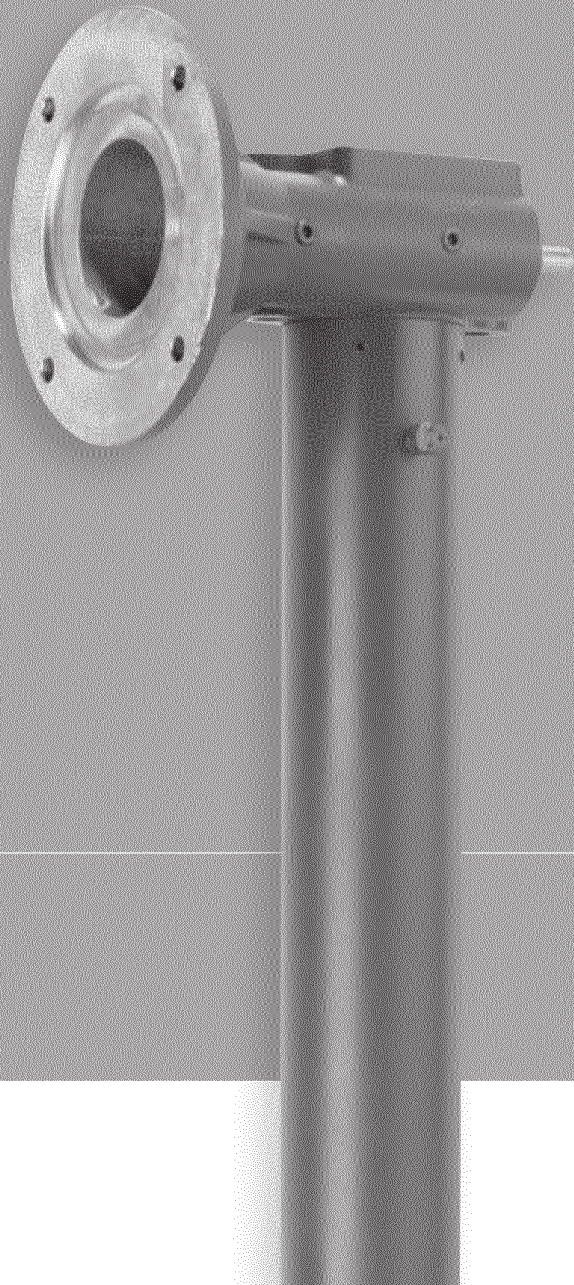

Joyce integrated actuators are designed to lift and precisely position loads of up to one ton. Translating tube (TT) integrated actuators are well suited for use in industrial environments where protection of the lifting screw mechanism is critical and low maintenance is desired. Traveling nut (TN) integrated actuators are best suited for use in environments that are relatively clean and free of dust.

Requiring only electric power, Joyce integrated actuators may be used in place of hydraulic cylinders, eliminating the cost and potential for leaks associated with hydraulic systems.

Integrated actuators include NEMA 56C-face motor flanges, and are capable of moving at speeds up to 345 inches per minute. Dynamic speed/load rating charts can be viewed along with product drawings on pages 139 to 142. Both acme screw (IA, DIA) and ball screw (BIA, HBIA) models are designed to operate at the charted capacities under both tension and compression loading.

Joyce Integrated Actuator Features and Benefits:

- Chrome plated (BIA, HBIA) or stainless steel (IA, DIA) inner cylinder tube resists harsh contaminants while providing smooth cylinder translation.
- Tube seals retain lubrication while preventing dirt and grime from entering the internal cavity and contaminating the lifting screw.
- Aluminum cast housing provides durable protection for screw and internal components.
- Rigid cylinder tube guide bearings provide resistance to buckling (external guides are required when side loads are present).
- Alloy steel input shafts riding on tapered roller bearings provide proper wormgear alignment for increased service life.
- Input shaft seals prevent the loss of lubrication.

Joyce/Dayton can customize integrated actuators to meet your specifications.

Joyce/Dayton offers Integrated Actuators in the following designs:

- Translating tube
- Traveling nut

An illustration and a guide for ordering are on pages 136 and 137.

INTEGRATED ACTUATORS ORDERING INFORMATION

Instructions: Select a model number from this chart.

ACME 1" diameter, .25" pitch	ACME 1" diameter, .25" pitch/.50" lead	Ball 1" diameter, .25" pitch	Ball 1" diameter, 1.00" pitch
IA51 IA201	DIA51* DIA201*	BIA51* BIA201*	HBIA51*



Important Note: *Integrated actuators may lower under load. Brake motors or external locking systems are recommended.

Sample Part Number: IA51-TT-6.00-LJ20-MMAA-S

Integrated Actuator Configuration	
TT Translating Tube	TN Keyed for Traveling Nut

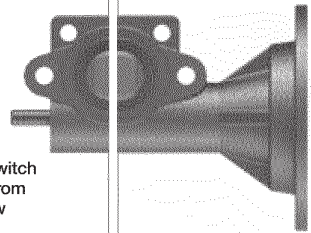
Integrated Actuator Rise
Rise is travel expressed in inches and not the actual tube length.

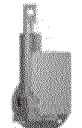
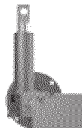
Left Side Shaft Code	Right Side Shaft Code
XXXX=Remove Shaft STDX=Standard LJ10 LJ20 LJ30 LJ40 See limit switch positions from chart below	 RMMT=Remove Motor Mount MMA=Standard Motor code from chart below

Limit Switches	1	2	3	4
Position				
Left side Shaft				
Code	LJ10	LJ20	LJ30	LJ40

Motors	
Size	Code
1/4 HP	K
1/3 HP	A
1/2 HP	B
3/4 HP	C
No Motor	X

Standard Motors					
Voltage	Speed (rpm)	1/4 HP	1/3 HP	1/2 HP	3/4 HP
115/230 VAC Single Phase	1140			X	X
115/230 VAC Single Phase	1725	X	X	X	X
115/230 VAC Single Phase w/brake	1725		X	X	X
230/460 VAC Three Phase	1140	X	X	X	X
230/460 VAC Three Phase	1725	X	X	X	X
230/460 VAC Three Phase w/brake	1725	X	X	X	X
12 VDC Permanent Magnet	1800	X	X	X	X
24 VDC Permanent Magnet	1800		X	X	X
90 VDC Permanent Magnet	1750	X	X	X	X
180 VDC Permanent Magnet	1750	X	X	X	X

Options** (see chart to left)	
X	No additional options
M	Modify standard actuator
C12	12 VDC motor
C24	24 VDC motor
C90	90 VDC motor
C180	180 VDC motor
K	Brake motor
R	1140 RPM motor
S	Single phase 115/230 3-ph. 60 Hz

** Specify as many options as needed.

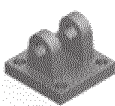
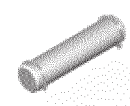
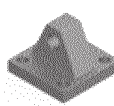
Optional Accessories (p. 138)		
		
Clevis Bracket 08040369	Pivot Pin with retaining rings CP-30	Eye Bracket 08040368

INTEGRATED ACTUATORS OPTIONS

Motors

Standard 56C-NEMA frame motors are available in:

AC Motors

- 1/4, 1/3, 1/2, and 3/4 HP
- 1140 or 1725 rpm
- Single or three phase
- With or without brake

DC Motors

- 1/4, 1/3, 1/2, and 3/4 HP
- 1750 rpm or 1800 rpm
- 90 and 180 volts

Ring Encoders

See pages 7 and 178.

Contact Joyce/Dayton with your requirements.

Limit Switch (LS7 ONLY)

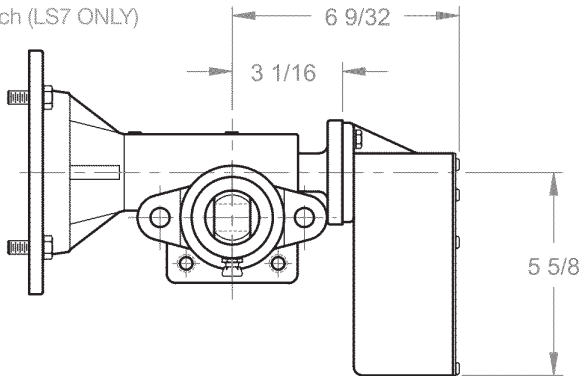

Limit Switch Position Nos.

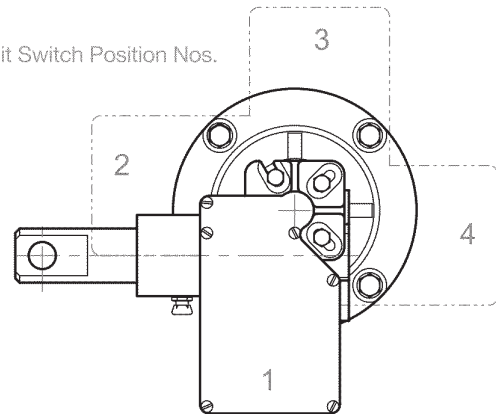

Clevis Accessories

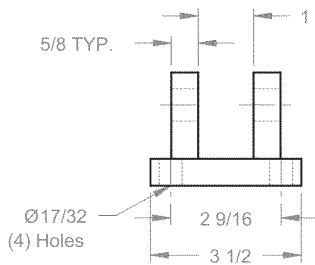

Clevis Bracket #08040369

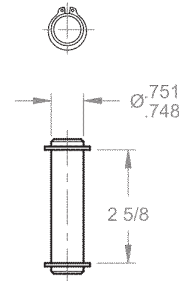
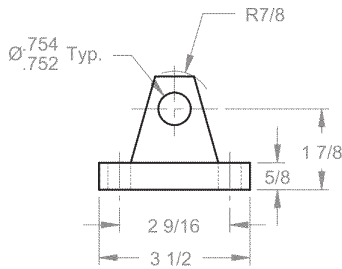

Pivot Pin
With Retaining Rings
CP-30

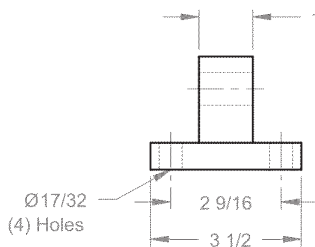

Eye Bracket #08040368

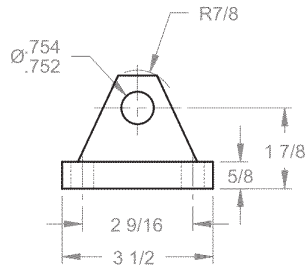

Note: Drawings are artist's conception — not for certification; dimensions are subject to change without notice.

INTEGRATED ACTUATORS

250-2000 POUND INTEGRATED ACME SCREW

IA 51TT / DIA 51TT
IA 201TT / DIA 201TT

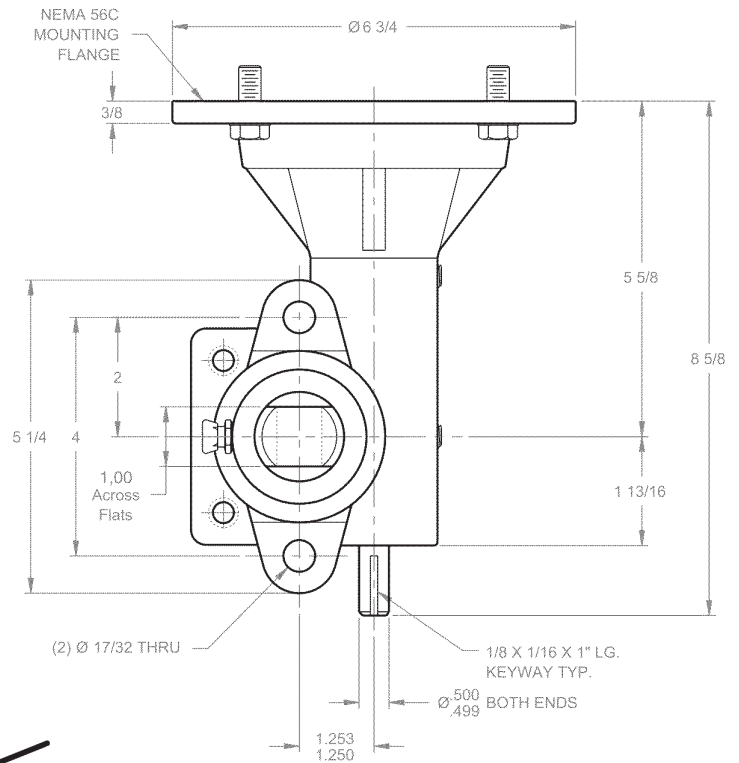
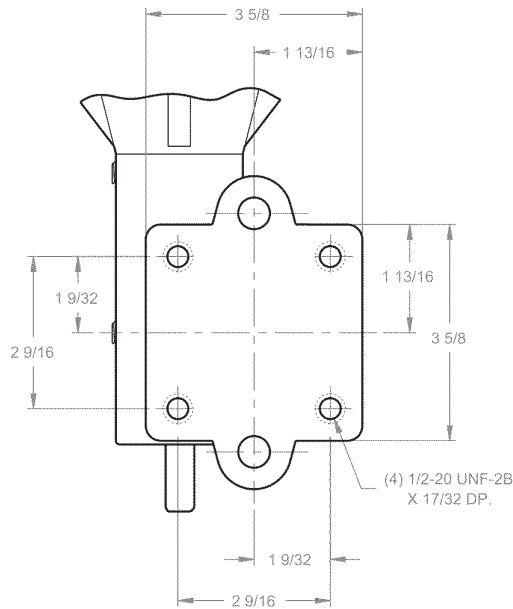

Model Number	IA51TT		DIA51TT		
	IA201TT		DIA201TT		
ACME Threaded Lifting Screw	1" diameter .25" pitch		1" diameter .25" pitch .50" lead		
Wormgear Ratio	5:1		5:1		
	20:1		20:1		
Worm Shaft Turns/1" Travel	20		10		
	80		40		
Motor RPM	1140	1725	1140	1725	
Lifting Speed (Inches/Minute)	57	86	114	172	
	14	21	28	43	
Rated Loads (Lbs.)	1/3 HP Motor	550	375	375	250
		1775	1225	1250	850
	1/2 HP Motor	850	550	575	400
		2000	1850	1875	1300
	3/4 HP Motor	1250	850	875	600
		2000	2000	2000	1950

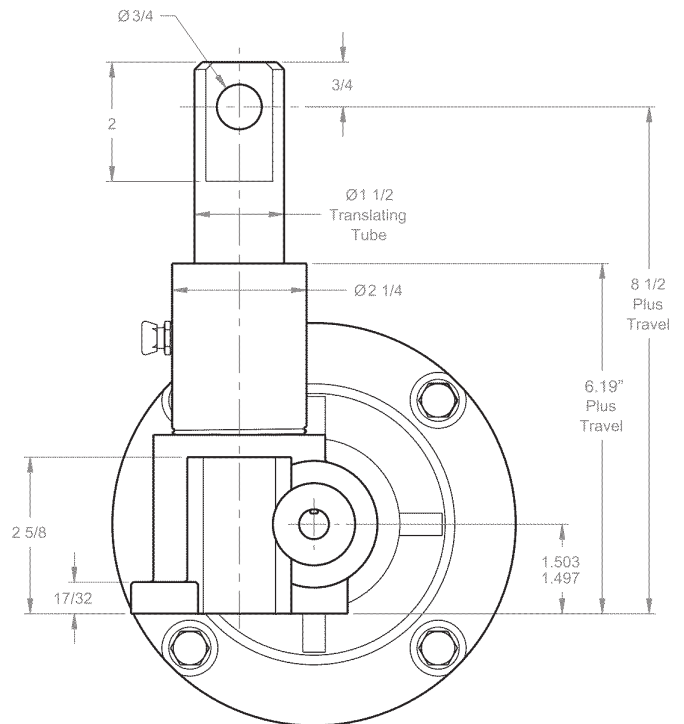

Lead: The distance traveled axially in one rotation of the lifting screw.
Pitch: The distance from a point on a screw thread to a corresponding point on the next thread, measured axially.
Important Note: DIA models may lower under load. Brake motors or external locking systems are recommended.

Note: Drawings are artist's conception — not for certification; dimensions are subject to change without notice.