



Power Select™ is an electric positioning system that can be supplied with a new distributor or as a retro-fit package for an existing distributor. Power Select™ utilizes a self contained hydraulic system to provide control for distributors with up to 24 outlets.

Each Power Select™ contains a hydraulic power unit that comes standard with 120V single phase electrical requirement. 480V 3 phase and Class II group G explosion proof units are also available options.

Solenoid Valves are mounted directly to the hydraulic power unit to reduce the chances of oil leakage.



DRIVE SYSTEM



CONTROL PANEL

The operator control station is supplied with every unit. This station is connected to the distributor power unit with standard electrical wire. Eight wires are required for distributors up to 12 holes and 9 wires are required for units with 13 to 24 holes.

Direct coupling of the Power Select™ drive unit provides simple trouble free operation and eliminates the chance of broken chains and sprockets and frozen slip clutches.

Proximity sensors provide all position information to the micro PLC that controls the system and makes decisions based on the input received from the operator station and the sensors.

Heavy duty hydraulic cylinders and motors provide the lift and rotation motions and are rated at over 1500 psi continuous duty usage.

POWER SELECT™	PRICE
For 6" to 18" units 4-12 Outlet Distributors 110/1/60 Electric Requirement Complete with Operator Station Panel	★

POWER SELECT™	PRICE
For 18" units or larger 10-24 Outlet Distributors 110/1/60 Electric Requirement Complete with Operator Station Panel	★

POWER SELECT™	PRICE
For 6" to 18" units 4-12 Outlet Distributors 460/3/60 Electric Requirement Complete with Operator Station Panel	★

POWER SELECT™	PRICE
For 18" units or larger 10-24 Outlet Distributors 460/3/60 Electric Requirement Complete with Operator Station Panel	★

OPTIONS:

Add to selected Power Select™ model to convert to Class 2, Group G Explosion. This rating applies only to the drive portion of the Power Select unit. The operator control station must be mounted in a non hazardous location. (Contact Premier Components for hazardous location control stations)	ADD ★
--	----------

Deduct from selected Power Select™ model if the Operator Control Station is not required. If the control signals will be provided from a central control computer the operator control station may not be necessary and can be eliminated from the system.	DEDUCT ★
--	-------------

MANUAL CONTROLS

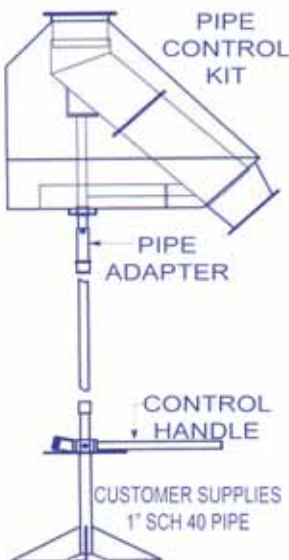

Pipe control kits are normally used where there is a direct line from the control to the distributor without obstruction. Each kit provides a rigid connection with a minimal amount of moving parts for less maintenance. Customers to supply their own Ø1" schedule 40 pipe.

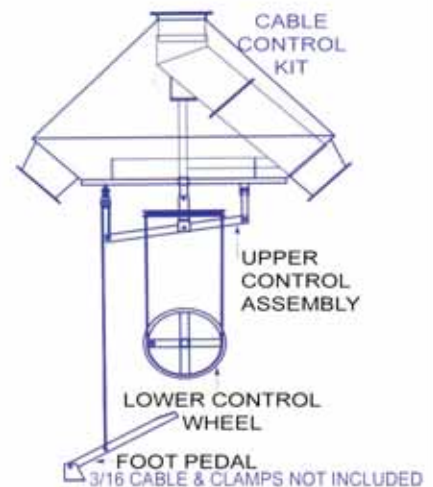

Cable control kits are primarily used where there are obstructions between the control and the distributor. Cables grant installers the option of go around augers or piping that may be in the direct path to the distributor. Customers to supply their own 3/16" cable and cable clamps.

DISTRIBUTOR DRIVES