

FEATURES

- ★ Non-rotating drive rod
- ★ Non-backdriving
- ★ All metal gearing
- ★ Compact with electric mechanical repeatability
- ★ Simple to mount; easy to wire
- ★ Comparable cost to pneumatic or hydraulic systems
- ★ Equivalent in size to hydraulic or pneumatic cylinders
- ★ Operating temperature range -40°F to +150°F



ADDITIONAL FACTORY DIRECT OPTIONS

ANDCO EAGLE MODEL 3100 ACME SCREW LINEAR ACTUATORS

STROKE LENGTH	115VAC, 1PH	230VAC, 3PH	460VAC, 3PH	575VAC, 3PH
UP TO 6"	★	★	★	★
UP TO 12"	★	★	★	★
UP TO 18"	★	★	★	★
UP TO 24"	★	★	★	★
UP TO 30"	★	★	★	★
UP TO 36"	★	★	★	★

STANDARD EQUIPMENT INCLUDES THE FOLLOWING FEATURES: CLASS B INSULATION, DUST IGNITION PROOF ENCLOSURE (NEMA 9, CLASS II, DIVISION 1, GROUPS E, F & G), (NOTE: A DUST-IGNITION PROOF ACTUATOR IS ALSO WEATHERPROOF), DOUBLE PULL / DOUBLE THROW LIMIT SWITCHES (DPDT), CLEVIS AND PIN (DRIVE ROD END) & CLEVIS MOUNT (MOTOR END)

OPTIONAL EQUIPMENT - FACTORY INSTALLED		PRICE ADDER
MOUNTING	ADJUSTABLE TRUNNION MOUNT	★
	ADJUSTABLE FACE/FLANGE MOUNT	★
MOUNTING	TRUNNION MOUNTING BRACKETS (PAIR)	★
BRACKETS	CLEVIS SWIVEL BRACKET (MOTOR END)	★
OVERSIZED ROD END CLEVIS		★
FEEDBACK: POTENTIOMETER (0-1000 OHM)		★
LIMIT SWITCH COMP'T HEATER (120VAC, 20w)		★
ROD COVER	6" - 12"	★
	18" - 24"	★
	30" - 36"	★
MANUAL OVER-RIDE HANDWHEEL		CALL

OPTIONS/EQUIPMENT FIELD-INSTALLED PRICING - FOR EXISTING ANDCO UNITS	
EAGLE FACE / FLANGE MOUNT KIT	★
FEEDBACK: POTENTIOMETER (0-1000 OHM)	CALL
DOUBLE PULL / DOUBLE THROW (DPDT) LIMIT SWITCH RETROFIT KIT (post 2001)	★
460VAC CONVERSION KIT (SINGLE PHASE TO THREE PHASE)	★
MOTOR, 115VAC, 1PH	★
MOTOR, 230VAC, 3PH	★
MOTOR, 460VAC, 3PH	★
MOTOR, 575VAC, 3PH	★
MOTOR, 230VAC, 1PH	★

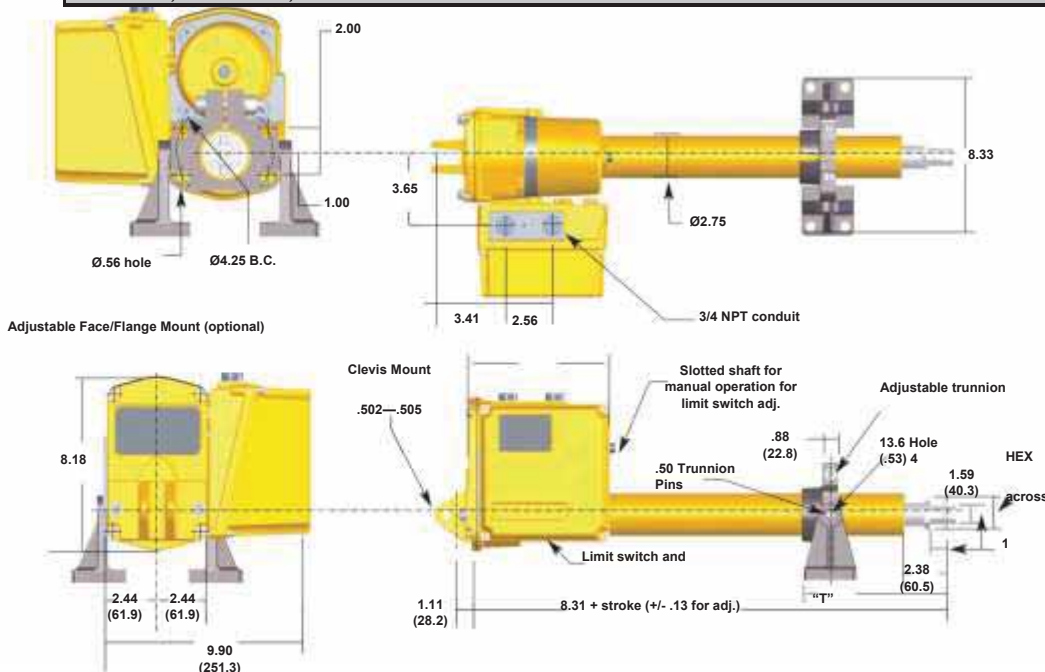

- NOTES**
1. Unbracketed dimensions are in inches
 2. Bracketed dimensions () are in millimeters
 3. Dimensions shown with actuator fully retracted

ADJUSTABLE TRUNNION OR FACE/FLANGE		
"T" Adjustable Dimensions		
Stroke	Inches	Millimeters
6	2.38 - 2.88	(60.45 - 73.15)
12	2.38 - 8.00	(60.45 - 203.20)
18	2.38 - 14.00	(60.45 - 355.60)
24	2.38 - 20.00	(60.45 - 508.00)
30	8.38 - 26.00	(212.85 - 660.40)
36	14.38 - 32.00	(365.25 - 812.80)

EAGLE ELECTRICAL CYLINDER PERFORMANCE				
3100 SERIES				
Velocity (in./sec.)	Breakaway Force (lbs.)	Running Force (lbs. @ 5% duty)	Weight Range (lbs.)	Stroke (in.)
0.2	2000	1000	35-75	6, 12
0.4	1500	750		18, 24
0.8	750	340		30 & 36
2.0	500	200		