

8 7 6 5 4 3 2 1

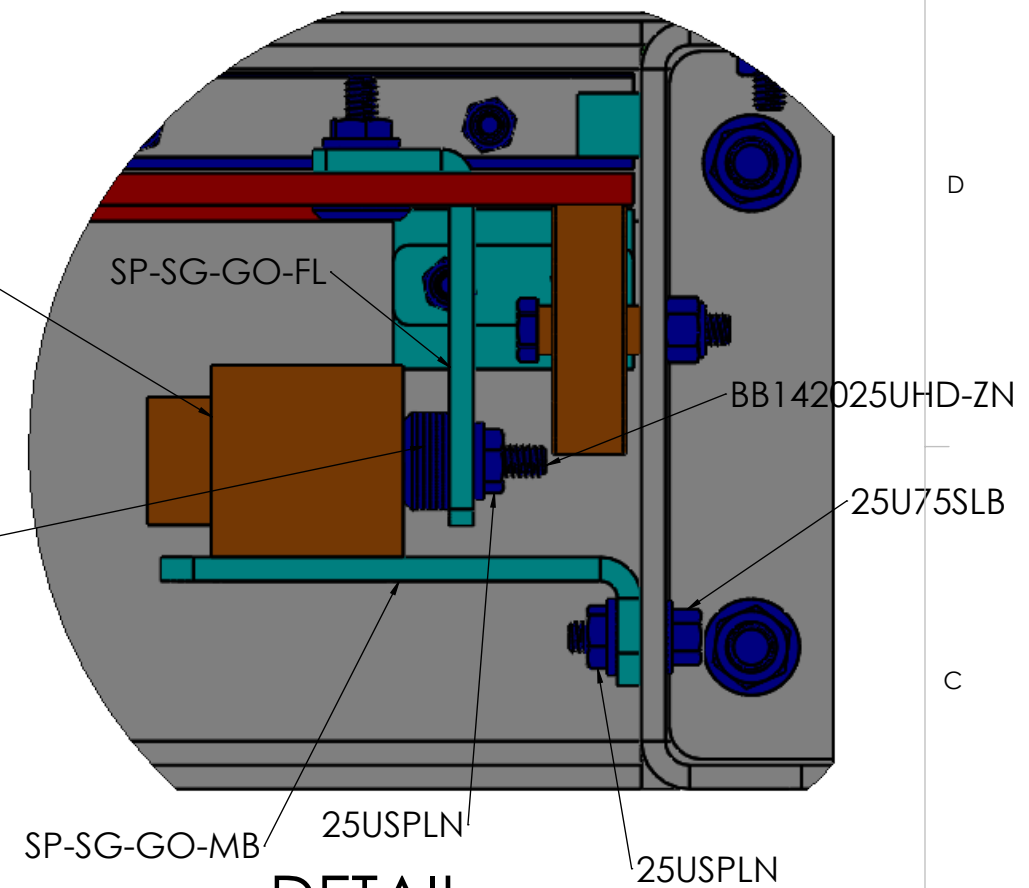

DETAIL A
SCALE 1:1.5

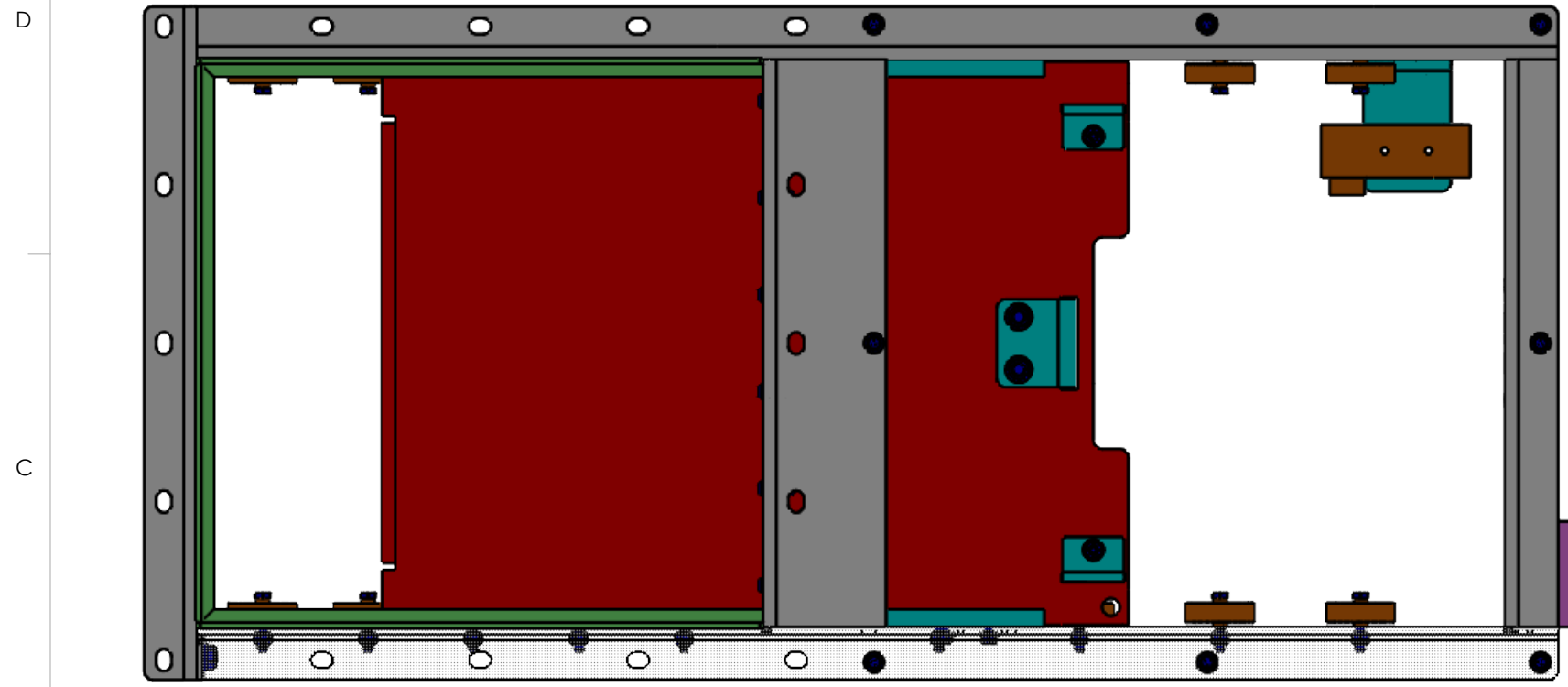
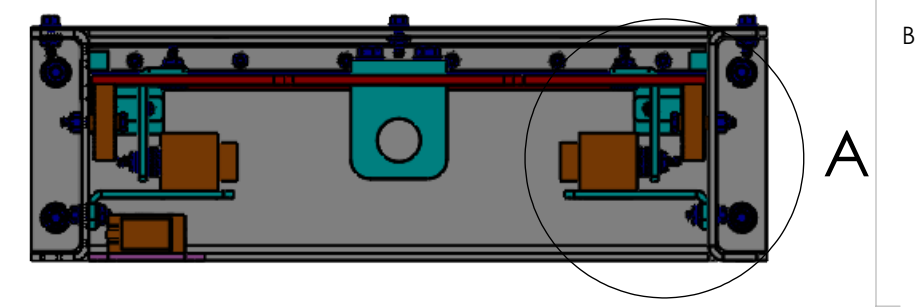
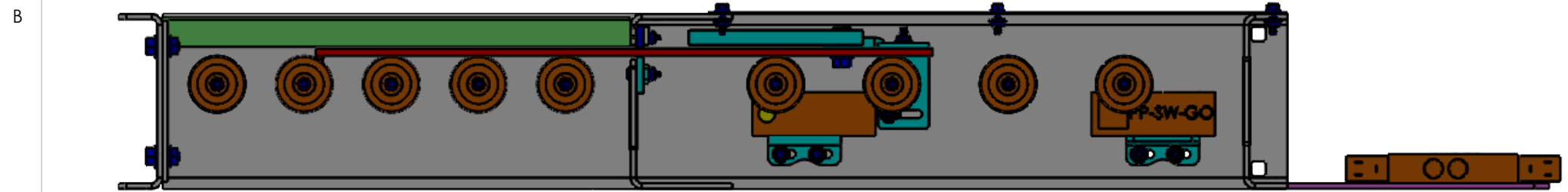

PART NO.:
SG-P1607

PROPRIETARY AND CONFIDENTIAL	DIMENSIONS ARE IN INCHES FRACTIONAL ± 1/16 ANGULAR: MACH ± .5° BEND ± 2° TWO PLACE DECIMAL ± .010 THREE PLACE DECIMAL ± .005	PART NAME:	ASSEM NO. SWITCH SETUP
		PART DESCRIPTION:	
MATERIAL:	WEIGHT:	DATE SAVED	Friday, November 8, 2019 1:41:41 PM

8 7 6 5 4 3 2 1